



Sodium Chlorite Solution Bulk Product Storage

Introduction

The following information on equipment for handling and storing sodium chlorite is meant to serve as a general guideline only. Consult product MSDS sheets for additional information.

The physical properties of the product are of prime importance when designing unloading and storage areas for sodium chlorite. In addition, the storage area, and all other areas where sodium chlorite is present, should be kept as clean as possible.

Storage System Requirements

A number of factors will influence the selection of materials and equipment for the storage of liquid sodium chlorite. Because extreme heat and cold can affect sodium chlorite solutions, it is important to maintain proper temperatures in storage areas. Storage temperatures should not exceed or 212 °F, (100°C). The storage area should not be exposed to direct sunlight or ultraviolet light. It should be fire resistant and have an effective sprinkler system and good ventilation.

Sodium chlorite solutions exceeding 31% concentration have a greater potential to crystallize at ambient temperatures. (See Figure). Normally, these products should be diluted prior to storage. Where bulk storage of concentrated solutions is required, the tank must be placed in a temperature-controlled location to ensure that the product is maintained at a temperature above its crystallization point. Direct heat should not be applied to the storage tank.

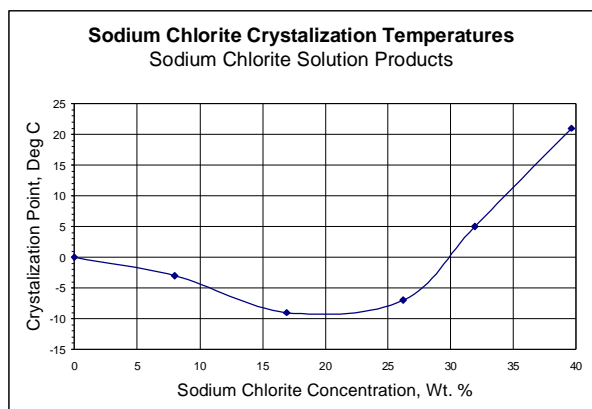

All equipment purchased for handling and storing sodium chlorite solutions should be verified by the manufacturer or vendor to be suitable for use with sodium chlorite.

A Piping and Instrument Diagram (P&ID) for a typical sodium chlorite solution storage system is included for reference.

Storage Tanks

Any containers used to store sodium chlorite solutions should be constructed of one of the following materials:

1. Fiberglass reinforced polyester with Hetrion 922 resin or equivalent, color natural, with UV protection, and no internal insulation.
2. High density polyethylene (HDPE)
3. Titanium

Sodium chlorite solution is most commonly stored in tanks constructed of fiber-glass-reinforced plastic (FRP). A FRP tank is constructed in layers of fiberglass and each layer is mixed with resin. The selection of the resin is extremely important, and the manufacturer should specify how each layer will be constructed and specify the correct type of resin for the specific application.

Sodium chlorite solution storage tanks normally should have at least a 5,000 gallon capacity to hold a full truck load of 4,200 gallons, or have a capacity that is 20% larger than the largest delivery. The storage tank should be of closed top construction to prevent product contamination. The tank vapor space should be adequately vented to prevent chlorine dioxide gas accumulation above explosive decomposition limits. Fiberglass tanks are not always designed to withstand pressure or vacuum so proper venting is critical, especially if the product is to be loaded into the tank with air pressure. The tank manufacturer should be consulted for a recommendation on proper vent openings and pressure/vacuum relief systems.

Tanks should be provided with nozzles to allow a local level and temperature indication. Nozzles should include truck-unloading vent, and pump suction as a minimum. Manways should also be provided to allow access to the interior of the tank. The tank manufacturer should be consulted for a recommendation on proper vent openings and pressure/vacuum relief systems.

Insulation is not normally required. Sodium chlorite storage tanks should never be insulated using organic-based or absorbent type (fiberglass) insulation.

PUMPS

- MODEL - SOLID STATE (SEE APPROPRIATELY)
- MATERIAL - 316 SS
- WOUND SIZES - (SIZE APPROPRIATELY)
- SEAL TYPE - CONTINUALLY RUNNING - DYNAMIC
- START / STOP - COUPLER MECHANIC

STORAGE TANKS

- MIN. SIZE - LARGEST DELIVERY PLUS 20 %
- DESIGN - FALSE BOTTOM TO INCLUDE COMPLETE DRAINAGE
- MAX. TEMP. RATING - 150°F
- PRESSURE - STATIC HEAD PLUS 2 FSD
- VAC. RATING - 10" W.G. PROPERLY VENTED TO PREVENT OVERPRESSURIZATION
- MATERIAL - 1/2" MIN. THICKNESS (OR EQUIVALENT), NO INTERNAL INSULATION, COLOR NATURAL, U.V. PROTECTION

NOTES:

1. TANK TRUCKS WILL BE ON BOARD AIR COMPRESSOR TO TRANSFER PRODUCT. IT WILL ALSO BE NECESSARY TO SPECIFY ACCEPTABLE G.P.M. TRANSFER RATE.
2. ALL PROCESS AREAS TO BE EQUIPPED TO DRAIN TO PROPER CHEMICAL SEWER.
3. RECOMMEND A TANK SUPPLIER BE SELECTED THAT WILL TAKE DESIGN RESPONSIBILITY FOR YOUR TANK. A LOCAL VENDOR MAY BE MORE PREFERRED COMPLETION ON A SINGLE TANK ACQUISITION.
4. IF HEAT TRACING IS USED, A TEMPERATURE CONTROLLER SHOULD BE USED TO KEEP FROM GENERATING ANY "HOT" SPOTS IN THE PIPING. HEAT TRACING TEMPERATURES SHOULD BE SPECIFIC FOR THE PRODUCT BEING USED.
5. CONSULT WITH REGULATORY AGENCIES FOR LOCAL ENVIRONMENTAL AND SAFETY REQUIREMENTS.

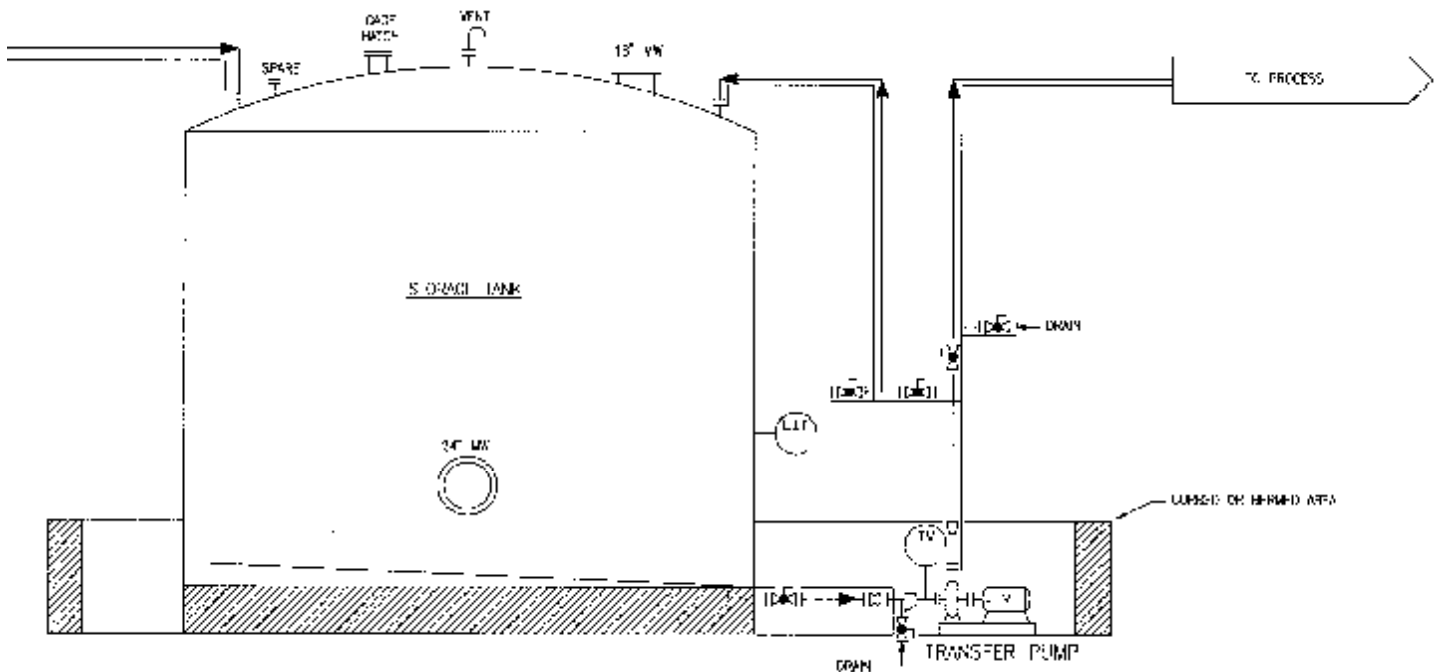

NO.	DATE	BY	CHKD BY	REV.

APPROVED FOR CONSTRUCTION WHEN SIGNED BELOW

VULCAN MATERIALS COMPANY
 CHEMICALS DIVISION
 WICHITA, KANSAS

PIPING & INSTRUMENT DIAGRAM
SODIUM CHLORITE SOLUTION STORAGE

SODIUM CHLORITE

SCALE	HDNE	BY	DWS	CHK
DATE	08-16-94	BY	TCH	CHK
DESIGN/REVISED	FILE NO.	DOC NO.	REV.	
	WD17704	17	1 5 12/04	

DRAWING HISTORY & REVISIONS

Instrumentation

All instrumentation will be local. The level transmitter should be of the extended diaphragm type to prevent possible solution freezing in the nozzle. All wetted parts should be Tantalum or equivalent. The local temperature transmitter should have a five-inch fall with a range of 0°F (-18°C) to 150°F (65 °C).

Pumps

Pumps should be a centrifugal type with all 316 SS wetted parts. The seal for the pump should be a double mechanical type. Motor for the pump should meet local requirements and codes.

Pumps are a typical source of leakage around glands and packing. This type of spillage should be promptly cleaned up and the area washed down with water. The water should then be drained into an industrial sewer in accordance with the regulations that govern wastewater discharges in your area. Greaseless lubricants should be used in areas where spilled material or dust from dried material may come in contact with the lubricants or the housings containing those lubricants.

Pumps should not be operated against closed valves. This may result in heating the sodium chlorite solution to above its decomposition temperature.

Piping

The recommended material is CPVC piping. Other materials such as vinyl ester FRP and Teflon piping may be used. Carbon steel and stainless steel are not recommended. Minimum pipe size should be 1½ inches.

Design the piping system to avoid spaces which may trap gases. The piping system should be designed to accommodate thorough flushing or complete drain down especially in cold climates where low temperatures may induce crystallization of the liquor in the piping system.

Heat tracing and insulation (calcium silicate or equivalent) may be appropriate where the solution freezing point is exceeded. However, if that approach is used, a temperature controller should be used to keep from generating any "hot" spots in the piping. Heat tracing temperature settings should be specific for the product being used.

Gaskets

Non-asbestos composition gaskets are commonly used in sodium chlorite liquid service. Gaskets constructed of Teflon®, EPDM (ethylene-propylene diene monomer), cross linked polyethylene, and Viton® are also used.

Spill and Leak Procedures

In the event of a spill or release, isolate the spill area and deny entry to unnecessary or unprotected personnel. Remove all sources of ignition, such as flames, hot glowing surfaces or electric arcs. Stop source of spill as soon as possible and notify appropriate personnel. Cleanup personnel must wear proper protective equipment. Notify all downstream water users of possible contamination.

Create a dike or trench to contain all liquid material. Spill materials may be absorbed using clay, soil or non-flammable commercial absorbents. Continue to keep damp. If allowed to dry, dried material can ignite in contact with combustible materials.

Sodium chlorite may represent an explosion hazard if it contacts acids or chlorine. If such contact is possible, evacuation procedures must be placed into effect. Evacuate all non-essential personnel. Hazardous concentrations in air may be found in local spill area and immediately downwind.

Do not place spill materials back in their original container. Containerize and label all spill materials properly. Decontaminate all clothing and, if permitted, the spill area using strong detergent and flush with large amounts of water.

Disposal

Sodium chlorite is toxic to fish and aquatic organisms. Do not discharge effluent containing this product into lakes, streams, ponds, estuaries, oceans or other waters unless in accordance with the requirements of a National Pollutant Discharge Elimination Systems (NPDES) permit and the permitting authority has been notified in writing prior to the discharge. Do not discharge effluent containing this product to sewer systems without previously notifying the local sewage treatment plant authority.

Spill residues may be a hazardous waste as defined in 40 CFR 261. The EPA hazardous waste designation for sodium chlorite solution waste would be D002. As a hazardous waste, it will be subject to the Land Disposal Restrictions under 40 CFR 268 and must be managed accordingly. As a hazardous waste solution or solid, it must be disposed of in accordance with local, state, and federal regulations in a permitted hazardous waste treatment, storage and disposal facility

Further Information

More detailed information on sodium chlorite is available on request through the OxyChem Technical Service Department. Call or write: Technical Service Department, OxyChem, 6200 South Ridge Road, Wichita, KS 67277 800-733-1165 option #1

www.oxy.com

Important: The information presented herein, while not guaranteed, was prepared by technical personnel and is true and accurate to the best of our knowledge. NO WARRANTY OF MERCHANTABILITY OR OF FITNESS FOR A PARTICULAR PURPOSE, OR WARRANTY OR GUARANTY OF ANY OTHER KIND, EXPRESS OR IMPLIED, IS MADE REGARDING PERFORMANCE, SAFETY, SUITABILITY, STABILITY OR OTHERWISE. This information is not intended to be all-inclusive as to the manner and conditions of use, handling, storage, disposal and other factors that may involve other or additional legal, environmental, safety or performance considerations, and OxyChem assumes no liability whatsoever for the use of or reliance upon this information. While our technical personnel will be happy to respond to questions, safe handling and use of the product remains the responsibility of the customer. No suggestions for use are intended as, and nothing herein shall be construed as, a recommendation to infringe any existing patents or to violate any Federal, State, local or foreign laws.