



Compressor Unloading of Methyl Chloride Tank Cars

Unloading Facilities

The design for a typical loading and transfer facility for compressor unloading of methyl chloride is depicted in the Piping and Instrument Diagram (P&ID) included in this Technical Data Sheet.

Methyl chloride unloading facilities should be located away from areas containing fired heaters and other potential ignition sources. All piping must be electrically bonded and provided with static electricity and lightning protection. Proper precautions and tools must be used when connecting or disconnecting methyl chloride tank cars to ensure a spark-free environment. The storage tank must be isolated from any plant process vent and recycle streams, to prevent possible contamination of the rail car.

Although methyl chloride may be unloaded from shipping containers using either a pump or a compressor, compressor unloading is recommended for most installations. Regardless of the method chosen, the shipping container and storage vessel should become a closed system to ensure no methyl chloride is released to the environment during unloading. Before unloading, all piping, including the unloading hose, must be purged and pressure tested with nitrogen to ensure there are no leaks. This nitrogen purge also removes oxygen and other contaminants in the piping. Unloading by use of nitrogen pressure is not recommended, as it will introduce high nitrogen levels into the methyl chloride product.

Tank Car Equipment

OxyChem tank cars are built and insulated to DOT specification 105-J-300W or 112-J-340W. Tank cars are available in 25,000, and 26,000 gallons capacities.

All connections to methyl chloride rail cars are located in the tank car dome (see Figure 1). These connections include two 2" liquid outlet valves and one 2" vapor valve along with a pressure relief valve, a thermowell and a sample valve. The vapor and liquid valves are equipped with 2" IPT female threaded connections. All valves are equipped with excess flow devices that shut off at a flow of 260 gallons/minute. The pressure relief valve is set to discharge at 225 psig or 255 psig, depending upon tank car design.

In addition, most OxyChem tank cars are equipped with a magnetic level gauge which operates in the top 50 percent of the tank. As required by DOT regulations, the normal filling and shipping density for tank cars is 86 percent.

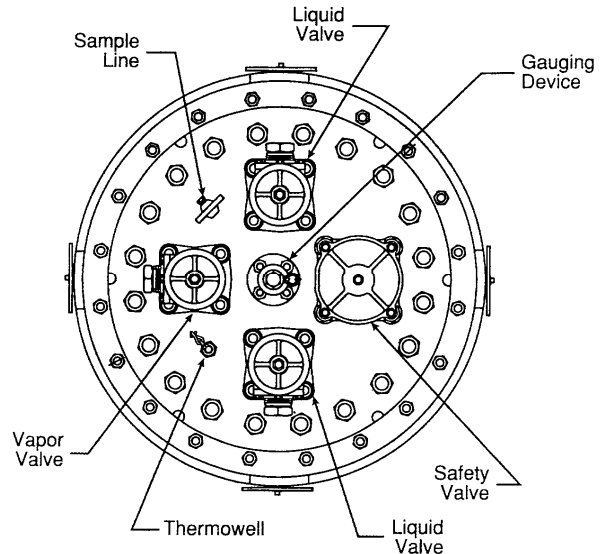

Figure 1
Valve arrangement for methyl chloride tank car
(Liquid valves are on the main axis of the tank car)

Compressor Unloading

When using a compressor to unload a tank car, compressed methyl chloride vapor from the storage tank is used to displace the liquid from the rail car to the tank (see Figure 2). Following transfer of the liquid, the compressor may be used to recover residual methyl chloride vapors from the tank car.

In this configuration, the liquid outlet of the tank car is piped to the storage tank liquid inlet. Compressor suction is piped to the storage vessel's vapor outlet while the compressor discharge is connected to the shipping container's vapor inlet. During unloading, a pressure differential of 10 to 15 psig is maintained across the compressor. Depending on the compressor's capacity, the discharge valve may need to be throttled to prevent seating the excess flow check valves.

During unloading, emergency equipment and personnel trained in its use should be readily available. Consult the MSDS to determine appropriate protective measures if exposure to methyl chloride above allowable limits is anticipated. After unloading is complete, all valve plugs must be reinstalled and tightened and the dome cover secured for the return trip.

Important: The information presented herein, while not guaranteed, was prepared by technical personnel and is true and accurate to the best of our knowledge. NO WARRANTY OF MERCHANTABILITY OR OF FITNESS FOR A PARTICULAR PURPOSE, OR WARRANTY OR GUARANTY OF ANY OTHER KIND, EXPRESS OR IMPLIED, IS MADE REGARDING PERFORMANCE, SAFETY, SUITABILITY, STABILITY OR OTHERWISE. This information is not intended to be all-inclusive as to the manner and conditions of use, handling, storage, disposal and other factors that may involve other or additional legal, environmental, safety or performance considerations, and OxyChem assumes no liability whatsoever for the use of or reliance upon this information. While our technical personnel will be happy to respond to questions, safe handling and use of the product remains the responsibility of the customer. No suggestions for use are intended as, and nothing herein shall be construed as, a recommendation to infringe any existing patents or to violate any Federal, State, local or foreign laws.

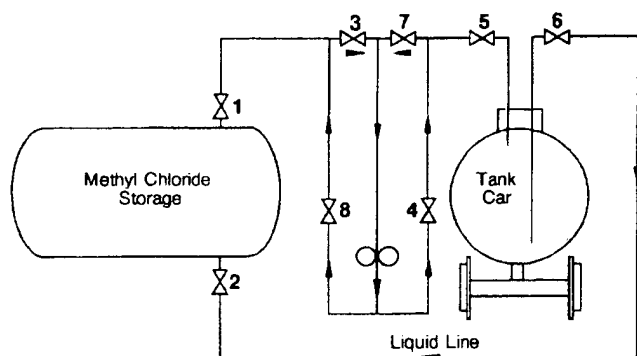

Figure 2
Compressor Unloading Schematic

Unloading Procedure

1. If storage pressure exceeds tank car pressure, open valves 1, 3, 7 and 5. Close valves 4 and 8 to equalize pressure.

If tank car pressure exceeds storage, open valves 2 and 6 to flow liquid until pressure equalizes.

2. Open valves 1, 3, 4 and 5. Close valves 7 and 8. Start compressor. Open valves 2 and 6 slowly and maintain differential pressure until all liquid is transferred.
3. After liquid is unloaded, the compressor suction is switched to the shipping container to vaporize the remaining liquid for transfer to the storage tank. During this step, all liquid valves must be closed. **Never allow pressure in the shipping container to fall below 10 psig.** Close valve 2 and open valve 1, 7, 8 and 5. Close valves 3 and 4. When tank car pressure falls to 10 psig, stop compressor. Close valves 5, 6, 1, 7 and 8.
4. Reinstall and tighten all shipping plugs. Inspect and prepare tank car for return per DOT guidelines.

Determination of Complete Unloading

The level detection device in the storage tank, or a liquid sensing probe in the unloading line should be used to determine when the car is empty. Other Indications that the rail car is empty include jumping of the unloading hose, the sound of vapor surging through the outlet line, or a drop in liquid line pressure.

NOTE: The tank car magnetic level gauge operates only in the top 50% of the tank, and cannot be used to determine when the car is empty.

Important: The information presented herein, while not guaranteed, was prepared by technical personnel and is true and accurate to the best of our knowledge. NO WARRANTY OF MERCHANTABILITY OR OF FITNESS FOR A PARTICULAR PURPOSE, OR WARRANTY OR GUARANTY OF ANY OTHER KIND, EXPRESS OR IMPLIED, IS MADE REGARDING PERFORMANCE, SAFETY, SUITABILITY, STABILITY OR OTHERWISE. This information is not intended to be all-inclusive as to the manner and conditions of use, handling, storage, disposal and other factors that may involve other or additional legal, environmental, safety or performance considerations, and OxyChem assumes no liability whatsoever for the use of or reliance upon this information. While our technical personnel will be happy to respond to questions, safe handling and use of the product remains the responsibility of the customer. No suggestions for use are intended as, and nothing herein shall be construed as, a recommendation to infringe any existing patents or to violate any Federal, State, local or foreign laws.

Unloading Equipment

Compressor

A two-stage, tandem, double distance dry cylinder gas compressor has been found to be acceptable for this application.

Corken Inc.
3805 NW 36th St.
Oklahoma City, OK 73112
405-946-5576
www.corken.com

Hoses

Connections to the rail car are normally made via flexible stainless steel braided hose (250 psi working pressure), with stainless steel threaded fittings. Alternately, this connection may be made with schedule 80 steel pipe, with swivel joints.

US Hose Corporation
815 Forestwood Dr
Romeoville, IL 60446
800-671-0033
www.ushosecorp.com

Microflex, Inc.
P O Box 730068
Ormond Beach, FL 32173-0068
386-677-8100
www.microflex.com

Further Information

More detailed information on methyl chloride is available on request through the OxyChem Technical Service Department. Call or write:

Technical Service Department
OxyChem
Post Office Box 12283
Wichita, Kansas 67277-2283
800-733-1165 Ext. 1
www.oxy.com